

SIMPSON

Strong-Tie

®

Cold-Formed Steel Construction Connectors



C-CFS12-APAC Expires 12/31/13

TABLE OF CONTENTS

Continuous Load Path Considerations	2	S/H, H & ULT Seismic & Hurricane Ties	14
Corrosion Information	18-19	S/HDU Holdowns	6
CS Coiled Straps	13	S/HTC Heavy Truss Clips	8
GCN150 Gas-Actuated Concrete Nailer	17	S/JCT & S/HJCT Steel Joist Hangers	11
HTT Tension Ties	5	S/LBV, S/B and S/BA Hangers	12
HUC Hangers	13	SP Stud Plate Ties	8
Important Information & General Notes	3-4	STC/DTC Roof Truss Clips	7
L & S/LS Reinforcing & Skewable Angles	9	TB Bridging	15
LTP5 Framing Anchor	9	TITEN HD®	
LTS Twist Straps	10	<i>Heavy Duty Screw Anchor for Concrete and Masonry</i>	16
MTSM/HTSM Twist Straps	10	TJC37 Jack Truss Connector	8
SCREWS Self-Drilling Fasteners	4	TP/TPA Tie Plates	6
S/DTT2Z Tension Tie	5	WBT Strap Tensioner	15
S/GTC Girder Truss Connector	7		

CONTINUOUS LOAD PATH CONSIDERATIONS

Modern design and construction practices use structural connectors to form a continuous load path that can effectively resist wind and seismic forces by reinforcing the structure from the roof to the foundation.

Simpson Strong-Tie® connectors are designed to enable structures to resist the movement, stress, and loading that results from natural events such as earthquakes and high velocity winds. When properly installed, our connectors will perform in accordance with the specifications set forth in this catalog, given the correct fastener is used, in the provided holes, into the recommended base material.

In cold-formed steel framing, connectors such as holdowns, straps, angles and hurricane ties are often field-fabricated. However, field-fabricated connectors in general have not been designed and tested to determine their ultimate and allowable load capacity and are typically not code listed. Field-fabricated connectors consume valuable man-hours on the jobsite and typically do not have prepunched holes. Because of this, the installer may not be properly locating the fasteners to achieve the intended design load.

Simpson Strong-Tie connectors are the most thoroughly tested and evaluated products in the industry, value engineered for the lowest installed cost at the highest rated performance levels. Our connectors save the contractor time in the field, and when properly specified and installed, provide an easier installation, at a lower installed cost, and are warranted for accuracy of design. This should be taken in consideration when considering field-fabricated connectors.

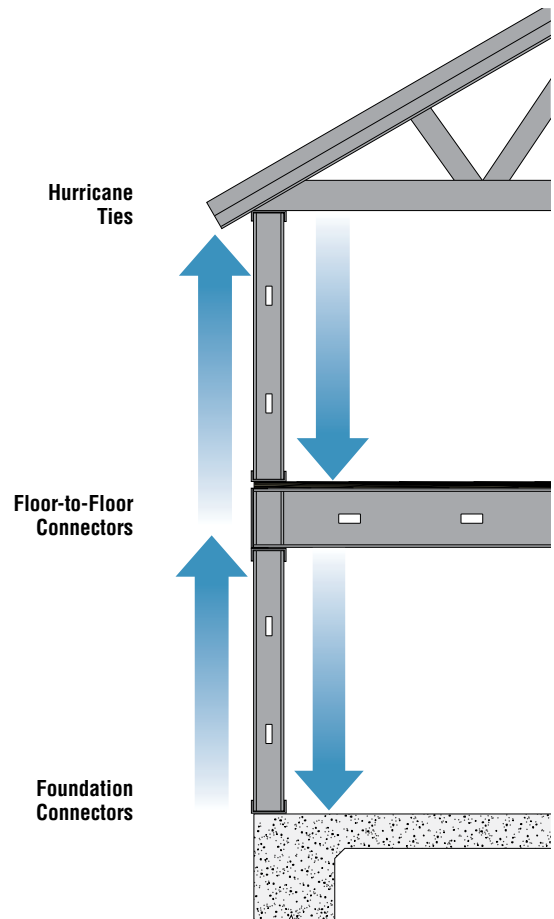

This shows a continuous load transfer path from the trusses to the foundation. A qualified Designer should ensure that correct quantities, fasteners and installation methods are used to achieve full design load values.

ACTIVE MEMBER



IMPORTANT INFORMATION & GENERAL NOTES

WARNING

Simpson Strong-Tie Company Inc. structural connectors, anchors, and other products are designed and tested to provide specified design loads. To obtain optimal performance from Simpson Strong-Tie® products and achieve maximum allowable design load, the products must be properly installed and used in accordance with the installation instructions and design limits provided by Simpson Strong-Tie Company Inc. To ensure proper installation and use, designers and installers must carefully read the following General Notes, General Instructions For The Installer and General Instructions For The Designer, as well as consult the applicable catalog pages for specific product installation instructions and notes.

Proper product installation requires careful attention to all notes and instructions, including these basic rules:

1. Be familiar with the application and correct use of the connector.
2. Follow all installation instructions provided in the applicable catalog, website, Pocket Installers Guide or any other Simpson Strong-Tie® publications.
3. Install all required fasteners per installation instructions provided by Simpson Strong-Tie Company Inc.: a) use proper fastener type; b) use proper fastener quantity; c) fill all fastener holes; d) do not overdrive or underdrive nails, including when using gun nailers; and e) ensure screws are completely driven.

4. Only bend products that are specifically designed to be bent. For those products that require bending, do not bend more than once.
5. Cut joists to the correct length, do not “short-cut”. The gap between the end of the joist and the header material should be no greater than 3.2mm unless otherwise noted.

In addition to following the basic rules provided above as well as all notes, warnings and instructions provided in the catalog, installers, designers, engineers and consumers should consult the Simpson Strong-Tie Company Inc. website at www.strongtie.com to obtain additional design and installation information.

Failure to follow fully all of the notes and instructions provided by Simpson Strong-Tie Company Inc. may result in improper installation of products. Improperly installed products may not perform to the specifications set forth in this catalog and may reduce a structure's ability to resist the movement, stress, and loading that occurs from gravity loads as well as short-term load even such as wind and earthquake loading.

Simpson Strong-Tie Company Inc. does not guarantee the performance or safety of products that are modified, improperly installed or not used in accordance with the design and load limits set forth in this catalog.

These notes are provided to ensure proper installation of Simpson Strong-Tie® products and must be followed fully.

- a. Simpson Strong-Tie Company Inc. reserves the right to change specifications, designs, and models without notice or liability for such changes.
- b. Steel used for each Simpson Strong-Tie® product is individually selected based on the product's steel specifications, including strength, thickness, formability, finish, and weldability. Contact Simpson Strong-Tie Company Inc. for steel information on specific products.
- c. Unless otherwise noted, dimensions are in millimeters, loads are in kilonewtons.
- d. Unless otherwise noted, welds, bolts, screws and nails may not be combined to achieve highest load value.
- e. Catalog loads are based on cold-formed steel members having a minimum yield strength, F_y , of 230 MPa and tensile strength, F_u , of 310 MPa for 1.09 mm and thinner, and a minimum yield strength, F_y , of 345 MPa and tensile strength, F_u , of 450 MPa for 1.37 mm and thicker. Steel thickness of 0.75, 0.95, 1.15, 1.55, and 1.95 millimeters with minimum yield strength, F_y , and tensile strength, F_u , of 550 MPa are also supported with these catalog loads.
- f. Unless otherwise noted, bending steel in the field may cause fractures at the bend line. Fractured steel will not carry load and must be replaced.
- g. Top flange hangers may cause unevenness. Possible remedies should be evaluated by a professional and include using a face mount hanger or cutting the subfloor to accommodate the top flange thickness.
- h. Built-up members (*multiple members*) must be fastened together to act as one unit to resist the applied load (*excluding the connector fasteners*). This must be determined by the Designer/Engineer of Record.
- i. Do Not Overload. Do not exceed catalog allowable loads, which would jeopardize the connection.
- j. Some model configurations may differ from those shown in this catalog. Contact Simpson Strong-Tie Company Inc. for details.
- k. Some combinations of hanger options are not available. In some cases, combinations

of these options may not be installable. Horizontal loads induced by sloped joists must be resisted by other members in the structural system. A qualified designer must always evaluate each connection, including carried and carrying member limitations, before specifying the product. Fill all fastener holes with fastener types specified in the tables, unless otherwise noted. Hanger configurations, height, and fastener schedules may vary from the tables depending on joist size, skew and slope. See the allowable table load for the non-modified hanger, and adjust as indicated. Material thickness may vary from that specified depending on the manufacturing process used. W hangers normally have single stirrups; occasionally, the seat may be welded. S/B, S/LBV, W and WP hangers for sloped seat installations are assumed backed.

- l. Simpson Strong-Tie Company Inc. will calculate the net height for a sloped seat. The customer must provide the H1 joist height before slope.
- m. Do not weld products listed in this catalog unless this publication specifically identifies a product as acceptable for welding, or unless specific approval for welding is provided in writing by Simpson Strong-Tie Company Inc. Some steels have poor weldability and a tendency to crack when welded. Cracked steel will not carry load and must be replaced.
- n. Steel for the framing members must comply with ASTM A 1003 Grade 33 (228 MPa) minimum, or Australian Standard™ AS1397, G550.
- o. Consideration should be given to the screw head specified as this may affect the attached materials.
- p. Do not add fastener holes or otherwise modify Simpson Strong-Tie® products. The performance of modified products may be substantially weakened. Simpson Strong-Tie Company Inc. will not warrant or guarantee the performance of such modified products.
- q. All references to bolts or machine bolts (MBs) are for structural quality through bolts (not lag screws or carriage bolts) equal to or better than ASTM Standard A307, Grade A.

Instructions to the Designer

- a. LRFD load is typically limited to an average or lowest test value (*nominal load*) multiplied by a resistance factor or the calculated value. The resistance factor is prescribed by Section F1 of AISI S100.
- b. Simultaneous loads in more than one direction on a single connector must be evaluated as follows:
Design Uplift/LRFD Uplift + Design Lateral Parallel to Track/LRFD Lateral Parallel to Track + Design Lateral Perpendicular to Track/LRFD Lateral Perpendicular to Track ≤ 1.0 . The three terms in the unity equation are due to the three possible directions that exist to generate force on a hurricane tie. The number of terms that must be considered for simultaneous loading is at the sole discretion of the Designer and is dependant on their method of calculating wind forces and the utilisation of the connector within the structural system.
- c. Loads are based on AISI S100, unless otherwise specified. Other code agencies may use different LRFD loads.
- d. The term “Designer” used throughout this catalog is intended to mean a licensed/certified building design professional, a licensed professional engineer, or a licensed architect.
- e. All connected members and related elements shall be designed by the Designer.
- f. Unless otherwise noted, member strength is not considered in the loads given and, therefore, reduce tabulated loads when member strength is limiting.
- g. The average ultimate breaking strength for some models is listed under “nominal tension load”.
- h. Simpson Strong-Tie Company Inc. strongly recommends the following addition to construction drawings and specifications: “Simpson Strong-Tie® connectors

and fasteners are specifically required to meet the structural calculations of plan. Before substituting another brand, confirm load capacity based on reliable published testing data or calculations. The Engineer/Designer of Record should evaluate and give written approval for substitution prior to installation.”

- i. Verify that the dimensions of the supporting member are sufficient to receive the specified fasteners, and develop the top flange bearing length.
- j. Simpson Strong-Tie Company Inc. will provide, upon request, code testing data on all products that have been code tested.
- k. Tabulated loads published in this catalog are for use when utilising the LRFD method per AISI S100.
- l. All steel-to-steel connector screws must comply with ASTM C1513.
- m. Screw strength shall be calculated in accordance to AISI S100 or shall be based upon manufacturers design capacity determined from testing.
- n. Simpson Strong-Tie Company Inc. recommends that hanger height be at least 60% of joist height for stability.
- o. Local and/or regional building codes may require meeting special conditions. Building codes often require special inspection of anchors installed in concrete and masonry. For compliance with these requirements, it is necessary to contact the local and/or regional building authority. Except where mandated by code, Simpson Strong-Tie® products do not require special inspection.
- p. When connectors are attached to 2 CFS members of different thicknesses, the Designer shall use the thinner of the 2 members for selecting allowable loads.

IMPORTANT INFORMATION & GENERAL NOTES

Instructions to the Installer

- All specified fasteners must be installed according to the instructions in this catalog. Incorrect fastener quantity, size, type, material, or finish may cause the connection to fail.
- Holes for 12.7 mm diameter or greater bolts shall be no more than a maximum of 1.6 mm larger than the bolt diameter per The American Iron and Steel Institute Specification S100 - 2007.
- Install all specified fasteners before loading the connection.
- Some hardened fasteners may have premature failure if exposed to moisture. The fasteners are recommended to be used in dry interior applications.
- Use proper safety equipment.
- When installing a joist into a connector with a seat, the joist shall bear completely on the seat. The gap between the end of the joist and the connector or header shall not exceed 3.2 mm per ICC-ES AC 261 and ASTM D1761 test standards, unless otherwise noted.
- For holdowns, anchor bolt nuts should be finger-tight plus $\frac{1}{8}$ to $\frac{1}{2}$ turn with a hand wrench. Care should be taken to not over-torque the nut, impact wrenches should not be used. This may preload the holddown.
- All screws shall be installed in accordance with the screw manufacturer's recommendations. All screws shall penetrate and protrude through the attached materials a minimum of 3 full exposed threads.
- Welding galvanized steel may produce harmful fumes; follow proper welding procedures and safety precautions. Welding should be in accordance with (AWS) standards. Unless otherwise noted Simpson Strong-Tie® connectors cannot be welded.
- Temporary lateral support for members may be required during installation.

Limited Warranty

Simpson Strong-Tie Company Inc. warrants catalog products to be free from substantial defects in material or manufacturing. Simpson Strong-Tie® products are further warranted for adequacy of design when used in accordance with design limits in this catalog and when properly specified, installed, and maintained. This warranty does not apply to uses not in compliance with specific applications and installation procedures set forth in this catalog, or to non-catalog or modified products, or to deterioration due to environmental conditions.

Simpson Strong-Tie® products are designed to enable structures to resist the movement, stress, and loading that results from impact events such as earthquakes and high velocity winds. Simpson Strong-Tie® products are designed to the load capacities and uses listed in this catalog. Properly-installed Simpson Strong-Tie® products will perform substantially in accordance with the specifications set forth on the website or in the applicable Simpson catalog. Additional performance limitations for specific products may be listed on the applicable catalog pages.

Due to the particular characteristics of potential impact events, the specific design and location of the structure, the building materials used, the quality of construction, and the condition of the soils involved, damage may nonetheless

result to a structure and its contents even if the loads resulting from the impact event do not exceed Simpson catalog specifications and Simpson Strong-Tie® products are properly installed in accordance with applicable building codes.

All warranty obligations of Simpson Strong-Tie Company Inc. shall be limited, at the discretion of Simpson Strong-Tie Company Inc., to repair or replacement of the defective part. These remedies shall constitute Simpson Strong-Tie Company Inc.'s sole obligation and sole remedy of purchaser under this warranty. In no event will Simpson Strong-Tie Company Inc. be responsible for incidental, consequential, or special loss or damage, however caused.

This warranty is expressly in lieu of all other warranties, expressed or implied, including warranties of merchantability or fitness for a particular purpose, all such other warranties being hereby expressly excluded. This warranty may change periodically – consult Simpson Strong-Tie Company Inc. for current information.

Fasteners

SCREWS Self-Drilling Fasteners

To achieve the loads shown in this catalog, the Designer must verify that the self-tapping screws used have load capacity equal to or greater than those shown in the table below.

Hex head screw sizes shown are required for connectors in this catalog. Where sheathing or finishes will be applied over the screws and low profile heads are needed, such as with bracing connectors, hurricane ties, and stud-plate ties, the Designer is to ensure that the minimum screw head diameter complies with ASME B18.6.4.

8g x 19mm 10g x 19mm 14g x 25mm

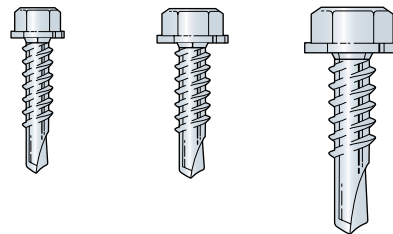

Shown
Actual Size

Minimum LRFD Loads for CFS Connector Screws

Screw Designation	Nominal Diameter d ⁿ (mm)	Washer Diameter d _w (mm)	LRFD Shear Loads (kN)						LRFD Tension Loads (kN)					
			(Φ*P _{ss})	Shear (Φ*P _{ns})					(Φ*P _{ts})	Tension: Pull-Out (Φ*P _{not})				
				Minimum Steel Thickness (mm)						Minimum Steel Thickness (mm)				
				0.75	0.95	1.15	1.55	1.95		0.75	0.95	1.15	1.55	1.95
8g	4.17	8.06	2.25	1.09	1.63	2.25	2.25	-	4.37	0.48	0.63	0.98	1.00	-
10g	4.83	9.53	3.69	1.18	1.76	3.56	3.69	3.69	5.87	0.56	0.73	1.21	1.46	2.38
14g ⁷	6.15	12.70	5.40	1.33	1.98	4.02	5.40	5.40	8.16	0.53	0.93	1.25	1.34	2.15

- The tabulated loads may be divided by a Resistance factor (Φ) of 0.50 to determine the screw nominal strength.
- Self-tapping screw fasteners for steel-to-steel connections used for connectors in this catalog shall be in compliance with ASTM C1513.
- Values are based on cold-formed steel (CFS) members with a minimum yield strength of F_y=230 MPa and tensile strength of F_u=310 MPa for 1.09mm and thinner and a minimum yield strength of F_y=345 MPa and F_u=450 MPa ksi for 1.37mm and thicker. Steel thickness of 0.75, 0.95, 1.15, 1.55, and 1.95 millimeters with minimum yield strength, F_y, and tensile strength, F_u, of 550 MPa are also supported with these catalog loads.
- Design thickness shall be the minimum base metal thickness divided by 0.95.
- Minimum required screw length is the greater of 19mm and the minimum length required for the screw to extend through the steel connection a minimum of (3) exposed threads per AISI S200-07 Sect. D1.3.
- Screw diameters per AISI S200-07 Table D1-1.
- 6.35mm diameter self-tapping screws may be substituted for 14g screws.

S/DTT2Z, HTT Tension Ties

The S/DTT2Z is a cost effective tension tie (holdown) that is commonly used for wood or steel sheathed cold-formed steel stud shear walls. It is intended for shear walls that have low overturning moment demand.

The HTT is a single-piece formed tension tie—no rivets, and a 4-ply formed seat. No washers are required.

The S/DTT2Z and HTT Tension Ties are ideal for retrofit or new construction projects. They provide high-strength, post-pour, concrete-to-steel connections.

MATERIAL: S/DTT2Z-1.74 mm
HTT4, HTT5 2.80 mm

FINISH: HTT-Galvanised, S/DTT2Z-G185

INSTALLATION: • Use all specified fasteners.

- Use the specified number and type of screws to attach the strap portion to the steel stud. Bolt the base to the wall or foundation with a suitable anchor; see table for the required bolt diameter.
- S/DTT2Z-A standard cut washer (provided) must be installed between the nut and the seat.

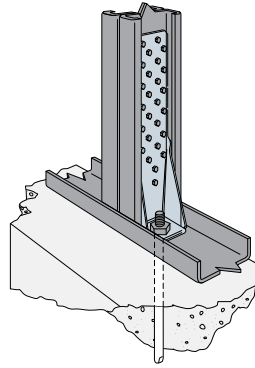

Typical HTT5 Installation as a Holdown

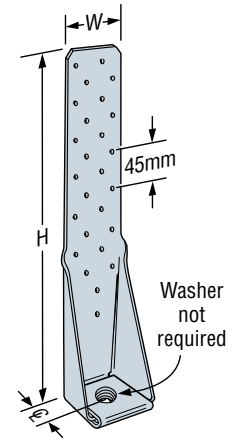

HTT5
(HTT4 similar)

U.S. Patent 5,467,570

Model	Dimensions (mm)			Fasteners		Stud Quantity	Stud Member Thickness (mm)	LRFD Tension Load (kN)	Deflection at LRFD Load ³ (mm)	Nominal Tension Load ⁴ (kN)
	W	H	ϕ	Fdn Anchor Diameter	Stud Fasteners					
S/DTT2Z	82	176	21	12	8 - 14g	1	0.75	9.8	6.4	19.0
						2	0.75	10.8	6.4	25.5
						1	0.95	10.5	6.4	24.8
HTT4	64	314	35	14	18 - 10g	1	0.75	21.2	4.7	36.5
						2	0.75	29.7	6.4	52.6
HTT5	64	406	35	14	26 - 10g	1	0.95	28.9	6.4	51.5
						2	0.95	31.0	6.4	54.2
						1	1.15	28.6	6.4	55.0

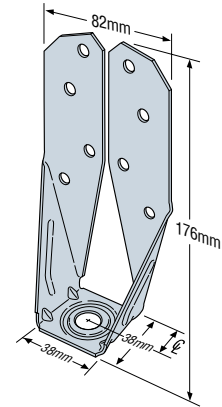

S/DTT2Z

1. The Designer shall specify the anchor embedment and configuration.
2. Stud design by Specifier. Tabulated loads are based on a minimum stud thickness for fastener connection.
3. Deflection at LRFD Loads is the deflection of the holdown measured between the anchor bolt and strap portion of the holdown when loaded to the LRFD load. This movement is strictly due to the holdown deformation under a static load test attached to members listed in the table.
4. Nominal Tension Load is based on the average ultimate (peak) load from tests. AISI Lateral Design standard requires holdown to have nominal strength to resist lesser of amplified seismic load or the maximum force the system can deliver.
5. THD12 anchor may be used with S/DTT's pre-packaged washer at 100% table load; without washer the adjustment factor is 0.75.
6. THD12 anchor may be used with HTT's.



S/DTT2Z Installed

S/HDU Holdowns

The S/HDU holdown combines performance with ease of installation. The pre-deflected geometry virtually eliminates material stretch, resulting in low deflection under load. Installation using self-drilling tapping screws into the studs reduces installation time and saves labor cost.

MATERIAL: 3.28mm

FINISH: Galvanised

INSTALLATION: • Use all specified fasteners.

See General Notes.

- Use 14g screws to fasten to studs

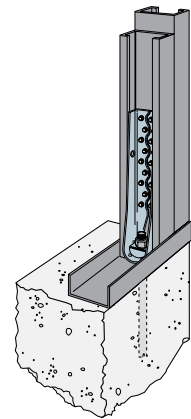
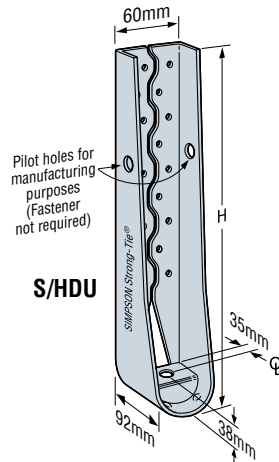

Typical S/HDU Installation

Model	H (mm)	Fasteners		Stud Quantity	Stud Member Thickness (mm)	LRFD Tension Load (kN)	Deflection at LRFD Load ⁴ (mm)	Nominal Tension Load ⁵ (kN)
		Fdn Anchor Diameter (mm)	Stud Fasteners					
S/HDU9	327	22	18 - 14g	2	0.75	49.5	4.8	58.6
				2	0.95	68.9	6.4	97.0
				2	1.15	71.0	5.7	108.9
				Steel Fixture	4.76	91.2	4.5	139.9

1. Designer shall specify the foundation anchor material type, length, embedment and configuration.
2. Stud design by Specifier. Tabulated loads are based on a minimum stud thickness for fastener connection.
3. Self-drilling tapping screws of 6.35 mm diameter can be substituted for 14g.
4. Deflection at LRFD Loads includes fastener slip, holdown elongation and anchor bolt elongation (L=102mm).
5. Nominal Tension Load is based on the average ultimate (peak) load from tests. AISI Lateral Design standard requires holdowns to have nominal strength to resist the lesser of the amplified seismic load or the maximum force the system can deliver.

Miscellaneous

TP/TPA Tie Plates

TPs are screw-on tie plates. TPAs are flanged for added support.

MATERIAL: 0.85mm

FINISH: Galvanised

INSTALLATION:

- Holes are sized for 8g or 10g screws.

Model No.	Dimensions (mm)		Number of Holes
	W	L	
TP15	46	127	13
TPA37	89	178	32
TPA39	89	229	41
TP35	79	127	23
TP37	79	178	32
TP39	79	229	41
TP311	79	279	50
TP45	105	127	30
TP47	105	178	42
TP49	105	229	54
TP411	105	279	66
TP57	146	178	60
TPA57	127	178	49

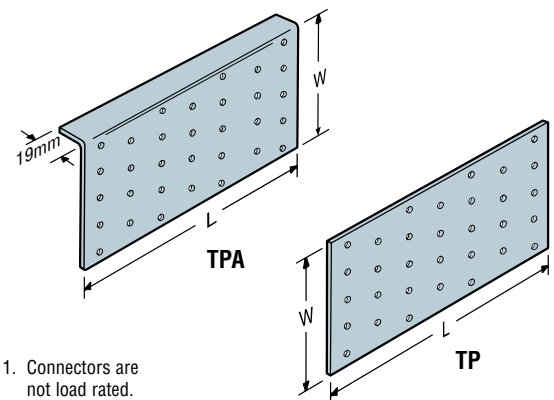

1. Connectors are not load rated.

STC/DTC Roof Truss Clips

For alignment control between a roof truss and nonbearing walls; the 38mm slot permits vertical truss chord movement when loads are applied.

MATERIAL: 1.13mm

FINISH: Galvanised

INSTALLATION: • Use all specified fasteners; see General Notes.

- Use STC or DTC depending on required loads.
- STC / DTC may be used with proprietary material sections. Contact material supplier for specific installation details.
- Install slot screws in the middle of the slot.

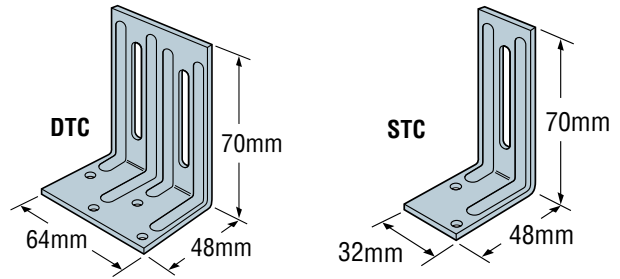

Model No.	Fasteners		LRFD Loads (kN)					
			Rafter/Stud thickness 0.75mm					
	Base	Slot	Without Gap		6.4mm Max. Gap		6.4 mm < Gap <= 12.7mm	
F ₁			F ₂	F ₁	F ₂	F ₁	F ₂	
STC	2 - 8g	1 - 8g	1.3	0.2	1.0	0.2	0.5	0.2
DTC	4 - 8g	2 - 8g	1.4	1.1 ³	1.5	1.1 ³	1.0	1.1 ³

1. Loads are based on attachment to a minimum 0.75mm steel thickness.
2. Truss or rafter must be bearing on top plate to achieve the allowable loads under "WITHOUT GAP."
3. Load at 3.2mm deflection for serviceability is 0.8 kN.

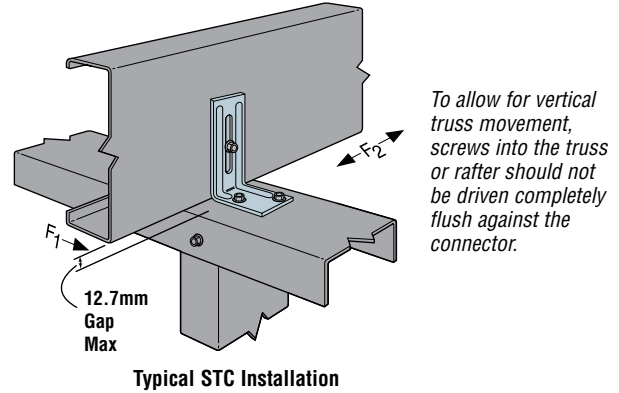

S/GTC Girder Truss Connector

The S/GTC truss connector is designed to connect a carried truss to a girder truss vertical member.

MATERIAL: 0.85mm

FINISH: Galvanised

INSTALLATION: • Use all specified fasteners; see General Notes.

- Install the connector onto the girder truss member first.
- May be used with proprietary material sections with web material dimensions from 35mm to 41mm. Contact material supplier for product specific installation details.

Model No.	Fasteners		Truss Material Thickness (mm)	LRFD Loads (kN)
	Carried Member	Carrying Member		
S/GTC	4 - 10g	4 - 10g	0.68	2.5
	4 - 10g	4 - 10g	0.75	3.0
	4 - 10g	4 - 10g	0.95	3.2
	4 - 10g	4 - 10g	1.15	3.4

1. Both girder and carried truss shall be laterally braced per Designer specification.
2. Loads are for one connector. Up to three connections may be installed; use an adjustment factor of 0.90 to total tabular load.

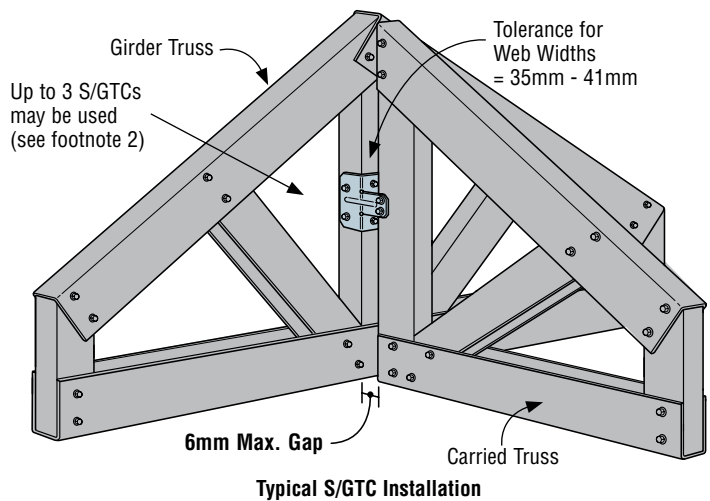
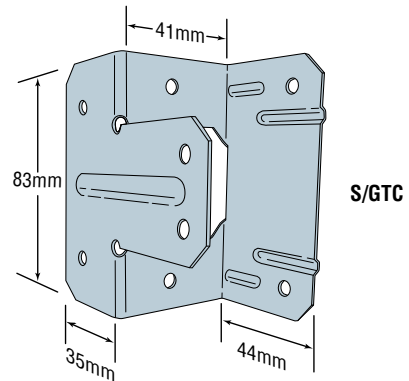

TJC37 Jack Truss Connector

TJC37 is a versatile connector for skewed members. Adjustable from 0 to 67.5 degrees (*shipped with 67.5 degree bend*). Screw hole locations allow for easy installation.

MATERIAL: 1.40mm

FINISH: Galvanised

INSTALLATION: • Use all specified fasteners; see General Notes.

- Can be installed filling round holes only, or filling round and triangle holes for maximum values.
- Position the skewed member on the inside of the bend line with the end of the member flush with the bend line.
- Bend the TJC37 to the desired position (*one bend cycle only*).

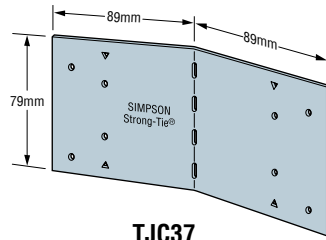

TJC37

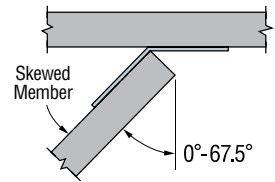

Top View Installation

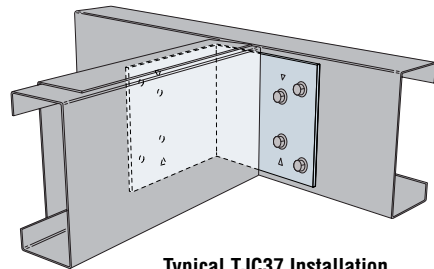

Typical TJC37 Installation

Model No.	Fasteners		LRFD Loads (kN) 0.95mm		
	Carrying Member	Carried Member	0°	1° - 60°	61° - 67.5°
			TJC37 (Min)	4 - 10g	4 - 10g
TJC37 (Max)	6 - 10g	6 - 10g	4.8	4.5	3.8

1. Loads are based on attachment to a minimum 1.09mm steel thickness.
2. Loads are for upward or downward direction.
3. Load at 3.2mm deflection for serviceability is 3.6 kN.

S/HTC Heavy Truss Clips

S/HTC provides a slotted connection from the truss or joist to the top track when isolation of two members is required.

MATERIAL: 1.13mm

FINISH: Galvanised

INSTALLATION: • Use all specified fasteners.

- Screws in vertical slots shall not be driven completely flush against the connector when vertical movement is desired.

Model No.	Fasteners		LRFD Loads (kN) 0.95mm				Serviceability Loads (kN) 3.2mm deflection 0.95mm			
	Base	Slot	Without Gap		32mm Max. Gap		Without Gap		32mm Max. Gap	
			F1	F2	F1	F2	F1	F2	F1	F2
S/HTC	4 - 8g	3 - 8g	2.2	3.1	0.8	1.4	1.9	2.3	0.5	1.2

1. Loads are based on attachment to a minimum 0.83 mm steel thickness.
2. Truss or rafter must be bearing on top plate to achieve the allowable loads under "WITHOUT GAP".
3. Installed with maximum 32 mm space between rafter or truss and top plate under "WITH 32 mm GAP." Where loads are not required, space is not limited to 32 mm.

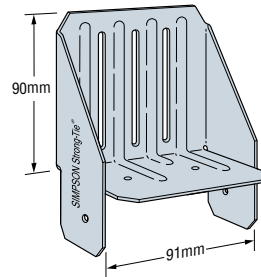

S/HTC4

Typical S/HTC4 Installation

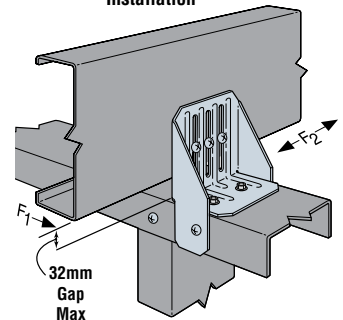

SP Stud Plate Ties

The SP stud plate tie is a plate-to-stud connection providing uplift resistance.

MATERIAL: 0.85mm

FINISH: Galvanised

INSTALLATION: • Use all specified fasteners.

Model No.	Dimensions (mm)		Stud Fasteners	LRFD Uplift Loads (kN) 0.75mm
	W	L		
SP4	91	184	6 - 10g	5.5
SP6	141	197	6 - 10g	5.5

1. Loads are based on attachment to a minimum 0.75mm steel thickness.

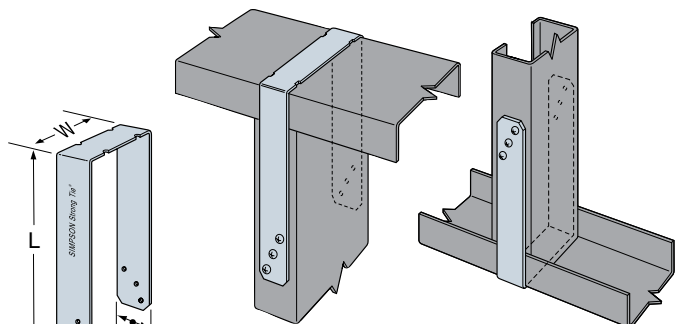

SP4

Typical SP Installation
(Wall to Top Track)

Typical SP Installation
(Wall to Bottom Track)

L&S/LS Reinforcing & Skewable Angles

L and S/LS angles are load rated and provide the correct thickness and number of fasteners the specifier is looking for compared with field fabricated clip angles.

General utility reinforcing angles with multiple uses.

S/LS—Field-adjustable angles attach members intersecting at angles.

MATERIAL: L—1.41mm; S/LS—1.13mm

FINISH: Galvanised

INSTALLATION: • Use all specified fasteners.

- S/LS—field-skewable; bend one time only.
- Joist must be constrained against rotation when using a single S/LS per connection.

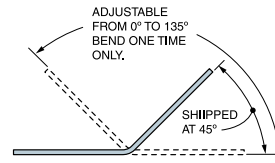

S/LS Top View

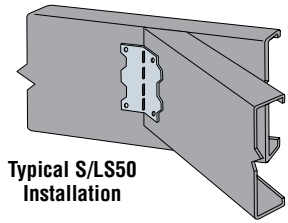

Typical S/LS50 Installation

Model No.	Length	Fasteners	LRFD Loads (kN) Rafter/Stud/Joist thickness					
			0.75mm		0.95mm		1.15mm	
			F1	F2	F1	F2	F1	F2
L30	76	4 - 10g	1.3	1.0 ²	2.2	1.0 ²	4.1	-
S/LS50	124	4 - 10g	1.3	-	2.6	-	3.3	-

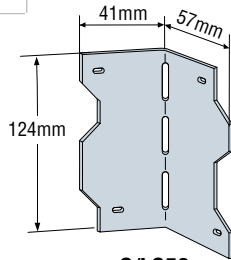

S/LS50

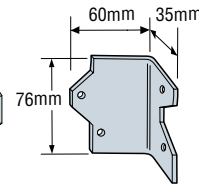

L30

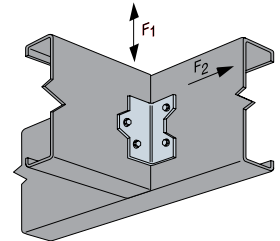

Typical L30 Installation

1. Loads are for one part only.
2. F2 direction loads at 3.2mm deflection for serviceability are 0.3 kN and 0.4 kN for 0.75mm and 0.95mm CFS respectively.

LTP5 Framing Anchor

The LTP5 framing anchor spans subfloor at the top of the blocking or rim joist. The embossments enhance performance and allow for design flexibility.

MATERIAL: 0.85mm

FINISH: Galvanised

INSTALLATION:

- Use all specified fasteners. See General Notes.

Model No.	Type of Connection	Direction of Load	Fasteners		LRFD Loads (kN) 0.95mm
			To Rim Joist	To Plates & Shearwall Sheathing	
LTP5	1	G	7 - 10g	7 - 10g	7.4
	2		7 - 10g	7 - 10g	7.9
	3		7 - nails 3.33mm x 38mm	7 - 10g	5.2

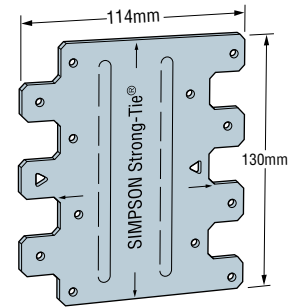

LTP5

1. Loads are for one part only.
2. Loads are based on attachment to a minimum 0.95mm steel (stud & sheathing) thickness.
3. Load for Type 3 connection assumes Cd = 1.60 per National Design Standard (NDS).

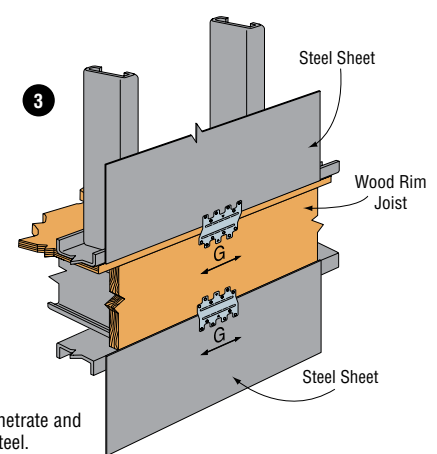
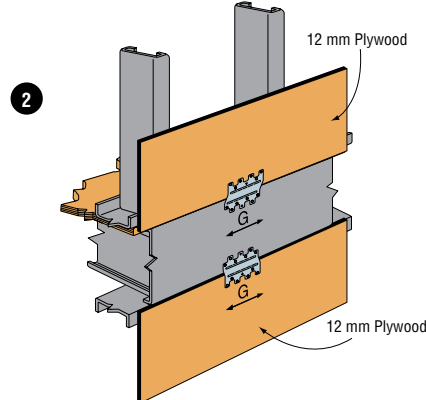
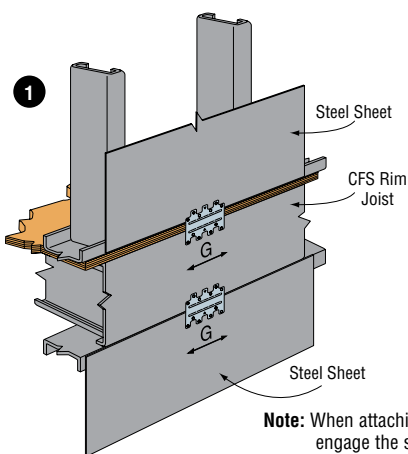

Note: When attaching an LTP5 framing anchor over sheathing, the screws must penetrate and engage the steel framing. A minimum of 3 threads shall penetrate past the steel.

LTS Twist Straps

Twist straps provide a tension connection between two members. They resist uplift at the heel of a truss economically. The 76mm bend section eliminates interference at the transition points between steel members.

MATERIAL: 1.13mm

FINISH: Galvanised

INSTALLATION: Use all specified fasteners. See General Notes.

Model No.	L (mm)	Fasteners (Total)			LRFD Uplift Loads (kN)
		Rafter/Stud/Joist thickness			
		0.75mm	0.95mm	1.15mm	
LTS12	305	10 - 10g	6 - 10g	6 - 10g	5.2
LTS16	406				
LTS18	457				
LTS20	508				

1. Loads are based on attachment to a minimum 0.75mm steel thickness.
2. Not all fastener holes need to be filled as additional fastener holes are provided. Install fasteners symmetrically.
3. Install half of the fasteners on each end of strap to achieve full loads.
4. All straps have the twist in the center of the strap.
5. Twist straps do not have to be wrapped over the truss to achieve the load.
6. May be installed on the inside flange of the stud.

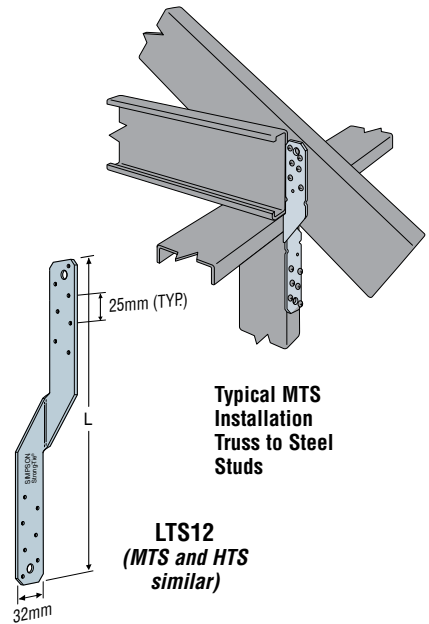

MTSM/HTSM Twist Straps

The MTSM and HTSM offer high strength truss to masonry connections.

MATERIAL: MTSM - 1.45mm; HTSM - 1.78mm

FINISH: Galvanised

INSTALLATION: • Use all specified fasteners. See General Notes.

- May be attached to either side of a grouted block wall. A minimum of one 16mm diameter horizontal rebar shall be installed in the top course of this wall.

Typical MTSM20 Installation

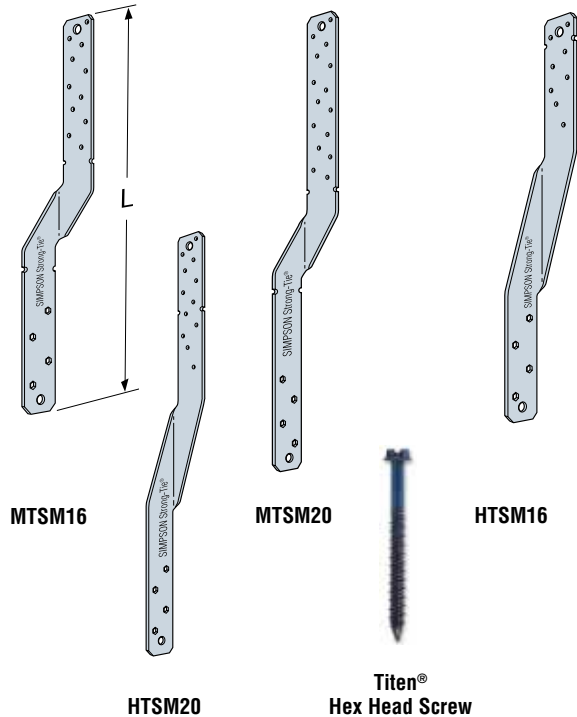
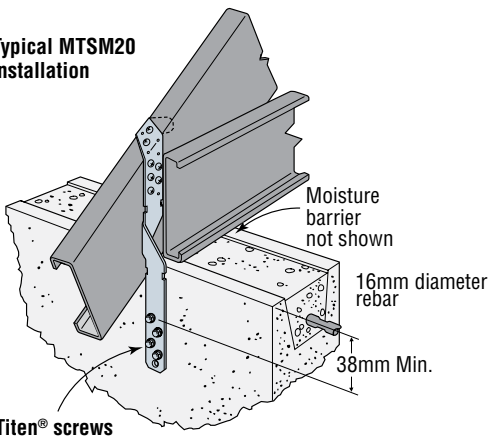

Model No.	L (mm)	Fasteners				LRFD Uplift Loads (kN)	
		Rafter/Stud/Joist Thickness			CMU		Concrete
		0.75mm	0.95mm	1.15mm			
MSTM16	406	6 - 10g	4 - 10g	3 - 10g	4 - 6.4mm x 57mm Titen Hex Head Screw	4 - 6.4mm x 32mm Titen Hex head Screw	6.8
MSTM20	508						
HTSM16	406	8 - 10g	6 - 10g	3 - 10g	4 - 6.4mm x 57mm Titen Hex Head Screw	4 - 6.4mm x 32mm Titen Hex head Screw	9.3
HTSM20	508						

1. All straps have additional fastener holes.
2. Twist straps do not have to be wrapped over the truss to achieve the tabulated loads.
3. Minimum edge distance in concrete block for Titen screw is 38mm.
4. May be installed on the inside face of the wall.
5. Min. $f_m = 10$ MPa and $f'_c = 17$ MPa.
6. Loads are based on attachment to a minimum 0.75mm steel thickness.

S/JCT & S/HJCT Steel Joist Hangers

New, improved, higher load-capacity joist hangers. Additional fasteners in the new S/JCT and the increased thickness of the S/HJCT increase the allowable load capacity for use with C-Joists. Joist can be attached from either side or doubled up. This hanger can be used with either steel or wood headers.

MATERIAL: S/JCT- 1.74mm; S/HJCT- 2.48mm

FINISH: Galvanised

INSTALLATION: • Attach hanger with specified fasteners.

Use round holes for minimum load, use round and triangle holes for maximum load.

- May be used for weld-on applications. The minimum required weld to the top flange is 3.2mm x 63.5mm fillet weld to each side of top flange.

Consult the code for special considerations when welding galvanised steel.

- FEATURES:**
- Uni-directional: Joist can be attached from left or right
 - One size fits joists 203mm through 356mm deep.
 - Optional holes for additional load capacity.
 - Simplicity of design.
 - Quick and easy installation.
 - Field skewable up to 45° left or right.

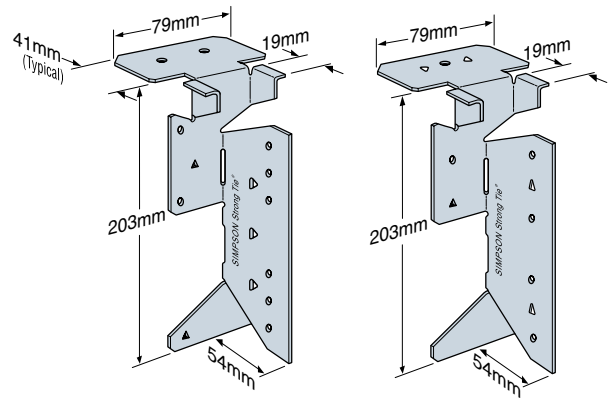

S/HJCT
U.S. Patent 6,230,467

S/JCT

Model No.	Cold-Formed Steel Header				
	Fasteners			LRFD Loads ¹ (kN)	
	Top	Face	Joist	Stud/Joist thickness 1.15mm	
			Uplift	Down	
Straight Hanger					
S/JCT (min)	1 - 10g	2 - 10g	4 - 10g	6.7	8.5
S/JCT (max)	1 - 10g	4 - 10g	6 - 10g	10.2	15.0
S/HJCT (min)	2 - 10g	4 - 14g	6 - 14g	10.7	20.8
S/HJCT (max)	2 - 10g	8 - 14g	9 - 14g	11.9	27.4 ²
Skewed Hanger					
S/JCT (min)	1 - 10g	2 - 10g	4 - 10g	6.7	8.1
S/JCT (max)	1 - 10g	4 - 10g	6 - 10g	6.7	8.4
S/HJCT (min)	2 - 10g	4 - 14g	6 - 14g	10.7	16.4 ³
Welded Hanger⁷					
S/JCT (min)	3.2mm x 63.5mm fillet weld to each side of top flange		4 - 10g	-	6.3
S/HJCT (min)			4 - 14g	-	10.3
S/HJCT Skew			4 - 14g	-	8.8

1. Loads are based on attachment to a minimum 1.15mm steel thickness.
2. Load at 3.2mm deflection for serviceability is 26.8 kN.
3. Load at 3.2mm deflection for serviceability is 14.4 kN.
4. Steel header must be braced to prevent web buckling per Designer specification.
5. Steel joist shall be laterally braced per Designer specification.
6. Screws shall be installed using joist hanger holes screwing through the hanger into the joist.
7. Backing in the steel beam cavity is not required behind the hanger for loads listed.
8. For joists with a 13mm gap (short cut) use an adjustment factor of 0.87.
9. For joists with a 13mm to 30mm gap (short cut) use an adjustment factor of 0.75.

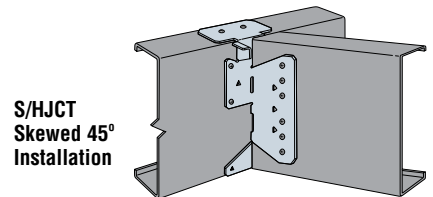

S/HJCT Skewed 45° Installation

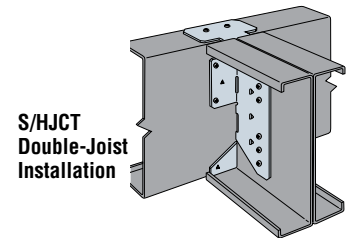

S/HJCT Double-Joist Installation

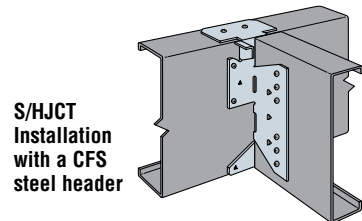

S/HJCT Installation with a CFS steel header

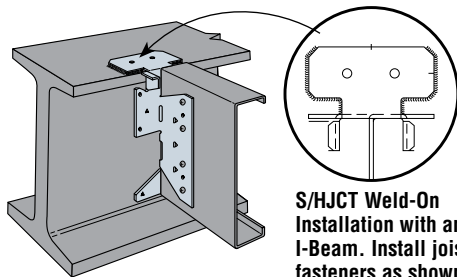

S/HJCT Weld-On Installation with an I-Beam. Install joist's fasteners as shown

S/LBV / S/B and S/BA Hangers

S/BA is the new Simpson Strong-Tie® top-flange hanger for cold-formed steel. The S/BA is a cost-effective alternative to heavier, special-order hangers. It is value engineered and tested to achieve higher allowable loads and increased performance. It may be fastened with screws or powder-actuated fasteners or welded to the header, providing more design options and greater versatility.

S/LBV and S/B hangers are manufactured with precision forming and quality control, providing dimensional accuracy and helping to ensure proper bearing area and connection.

MATERIAL: S/LBV, S/BA – 1.78mm; S/B – 2.51mm

FINISH: Galvanised

INSTALLATION:

- S/LBV, S/B, and S/BA may be used for weld-on applications; a minimum of 3mm x 51mm fillet weld on each top flange is required. Distribute the weld equally on both top flanges. Consult the code for special consideration when welding galvanised steel. Uplift loads do not apply.
- S/BA may be installed using powder-actuated fasteners. PDPAT-62KP (4mm x 16mm) powder-actuated fastener shall be installed using the appropriate level of powder load so the entire pointed portion of the fastener penetrates through the steel. A powder-actuated fastener with a “tophat” crush sleeve is recommended in case the head of the fastener is not fully flush with the connector.
- Installation of powder-actuated fasteners may vary due to, but not limited to, the type of powder-actuated tool, cleanliness of tool, type of powder load and steel.

OPTIONS: Skew only:

- S/LBV and S/B series can be skewed to a maximum of 45 degrees.
- Available through special order.

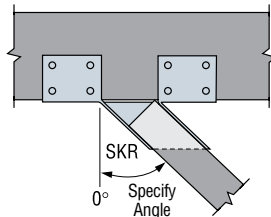

Top View S/B Hanger Skewed Right

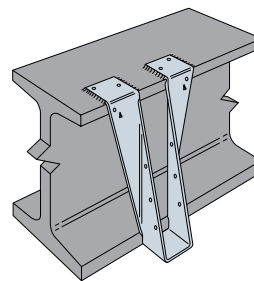
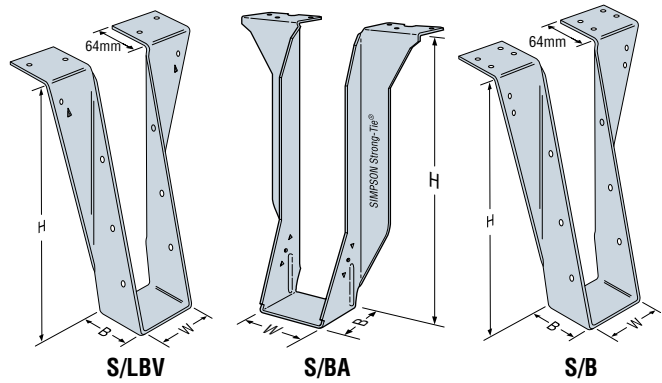

S/LBV, S/B, and S/BA are acceptable for weld-on applications (S/LBV shown)

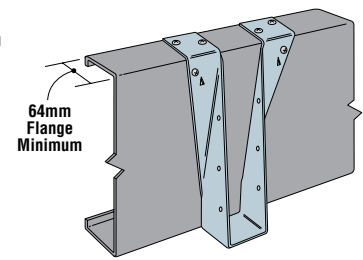

S/LBV Installation with a CFS steel header

Model	Dimensions (mm)			Fasteners			LRFD Loads (kN)	
	W	H	B	Top	Face	Joist	Uplift	Down
Cold-Formed Steel Header – Straight Hanger								
S/LBV	See Table	152 to 508	57	4 - 10g	2 - 10g	3 - 10g	7.2	22.4
S/B		152 to 762	76	8 - 10g	4 - 14g	3 - 14g	13.2	42.4
Cold-Formed Steel Header – Skewed Hanger								
S/LBV	See Table	152 to 508	27	4 - 10g	2 - 10g	3 - 10g	7.2	15.8
S/B		152 to 762	76	8 - 10g	4 - 14g	3 - 14g	13.2	29.9
Powder-Actuated Fastener or Welded to Steel Header – Straight Hanger								
S/LBV	See Table	152 to 508	57	4 - 3mm x 50mm fillet weld to each side of top flange	-	3 - 10g	-	21.1
S/B		152 to 762	76		-	3 - 14g	-	41.0

- Designer shall ensure that the joist member adequately transfers load to hanger.
- Cold-formed steel / steel-beam header must be braced to prevent buckling per Designer specification.
- Powder-actuated fasteners may be installed in up to 10mm steel headers having a minimum $F_y=248\text{MPa}$.
- Load is based on using the Simpson Strong-Tie® PDPAT-62KP powder-actuated fastener and a minimum Red (level 5) powder load.
- Tabulated loads are based on testing with full bearing of 64mm flange-depth minimum thickness of 1.55mm joists for S/LBV and S/BA hangers and 1.95mm joists for S/B hangers.

S/LBV Series Model No.	W (mm)	H (mm)
S/LBV1.81x08	46	203
S/LBV1.81x10	46	254
S/LBV1.81x12	46	305
S/LBV3.56x08	90	203
S/LBV3.56x10	90	254
S/LBV3.56x12	90	305

S/B Series Model No.	W (mm)	H (mm)
S/B1.81x08	46	203
S/B1.81x10	46	254
S/B1.81x12	46	305
S/B3.56x08	90	203
S/B3.56x10	90	254
S/B3.56x12	90	305

HUC Hangers



MATERIAL: 1.74mm
FINISH: Galvanised
INSTALLATION:

- HUC series hangers may be welded to supporting structural steel members.
- Use 25mm weld segments equally spaced top and bottom, with half the segments on each side of hanger.
- Welds may be either Lap Joint (on outside edge of flanges) or Flare-Bevel Groove (on flange bend line).

Model Series	Connection Type		Maximum LRFD Down Load (kN)
	Joist	Structural Steel	
	Screw	Weld	
HUC	10g	4 - 25mm segments	20.1
	10g	6 - 25mm segments	32.4

1. Loads assume a 0.48 kN/mm² minimum tensile filler metal.
2. Welds must conform to the current A.W.S. D1.3 structural welding code for sheet steel and must be performed by certified welder.
3. Designer shall insure that the joist member adequately transfers load to hanger.
4. Hanger to joist connection shall be made using screws on the side of the hanger where it meets the web of the joist.

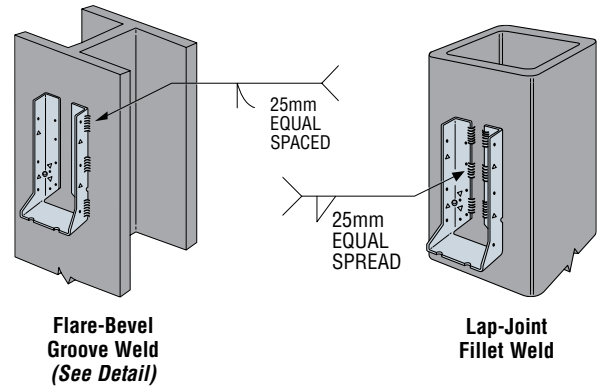
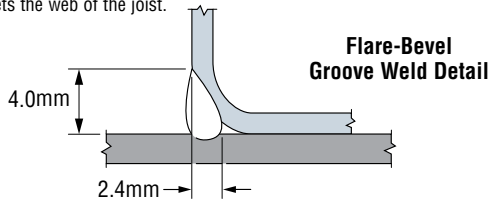

Installation for CFS Built-Up Beam
 The Designer is responsible for design of beam member.

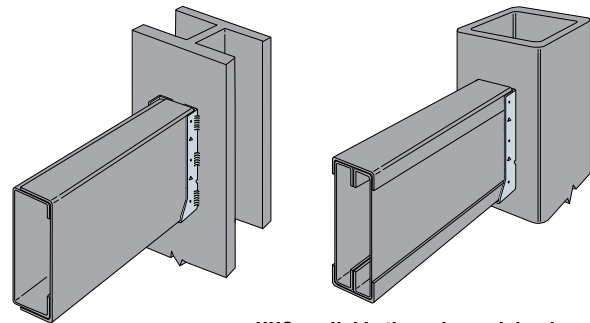

Straps & Ties

CS Coiled Straps

CS are continuous utility straps which can be cut to length on the job site. Packaged in lightweight (**about 18kg**) cartons.

FINISH: Galvanised

INSTALLATION: • Use all specified fasteners.
 See General Notes.

- Refer to the applicable code for minimum edge and end distances.
- The table shows the maximum loads and the screws required to obtain them. See footnote #1. Fewer screws may be used; reduce the load by the code lateral load for each fastener subtracted from each end.

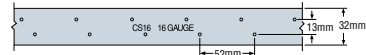

CS16 Hole Pattern
 (all other CS straps similar)

Gauge stamped on part for easy identification

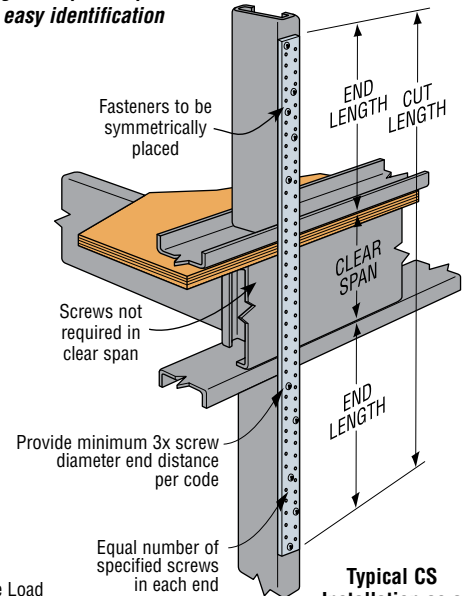

Model No.	Total Length (m)	Width (mm)	Fasteners (Total)			LRFD Uplift Loads (kN)
			Rafter/Stud/Joist Thickness			
			0.75mm	0.95mm	1.15mm	
CS14	30.5	32	28 - 10g	18 - 10g	12 - 10g	15.4
CS16	45.7		18 - 10g	12 - 10g	8 - 10g	10.3
CS18S	30.5		14 - 10g	10 - 10g	6 - 10g	8.2
CS18	61.0		14 - 10g	10 - 10g	6 - 10g	8.2
CS20	76.2		12 - 10g	8 - 10g	6 - 10g	6.3
CS22	91.4		10 - 10g	6 - 10g	6 - 10g	5.2

1. Use half of the fasteners in each member being connected to achieve the listed loads.
2. Loads are based on attachment to a minimum 0.75mm steel thickness.
3. For CS straps: End Length (mm) = 12.7 x Total Fasteners + 25.4mm
4. Total Cut Length = End Length + Clear Span + End Length.
5. Calculate the connector value for a reduced number of screws as follows: Load = $\frac{\text{No. of Screws Used}}{\text{No. of Screws in Table}} \times \text{Table Load}$

Example: CS16 on 0.75mm with 10 screws: $\frac{10 \text{ Screws (Used)}}{18 \text{ Screws (Table)}} \times 10.3 \text{ kN} = 5.7 \text{ kN}$

6. Loads are based on lesser of steel strap capacity and AISI S100 - 2007 fastener calculation.

S/H, H & ULT Seismic & Hurricane Ties

Designed to provide seismic and wind ties for trusses or joists, this versatile line may be used for general tie purposes, strongback attachments, and as all-purpose ties where one member crosses another.

MATERIAL: See table

FINISH: Galvanised

INSTALLATION: • Use all specified fasteners.

- Hurricane ties do not replace solid blocking.
- H6 ties are only shipped in equal quantities of rights and lefts.

Model No.	Connector Material Thickness (mm)	Fasteners			LRFD Loads (kN)		
		To Rafters / Truss	To Top Track	To Stud	Uplift	Lateral ³	
					F1	F2	
S/H1	1.13	3 - 10g	2 - 10g	1 - 10g	2.2	0.4	0.5
H2A	1.13	5 - 10g	1 - 10g	5 - 10g	3.2	0.4	0.4
S/H2.5	1.13	4 - 10g	-	4 - 10g	2.8	0.4	0.6
S/H3	1.13	2 - 10g	2 - 10g	-	2.7	0.4	0.6
ULT	1.13	3 - 10g	2 - 10g	3 - 10g	3.4	1.2	1.8
H6	1.40	-	8 - 10g	8 - 10g	4.2	-	-

1. Loads are based on attachment to a minimum 0.75mm steel thickness.
2. Hurricane ties are shown installed on the outside of wall for clarity. Installation inside of wall is acceptable. For Continuous Load Path, connections in the same area must be on same side of wall.
3. Lateral Loads are limited to 3.2mm deflection for serviceability.
4. ULT with CFS members having a minimum thickness of 0.95mm the LRFD uplift load is 4.75kN.

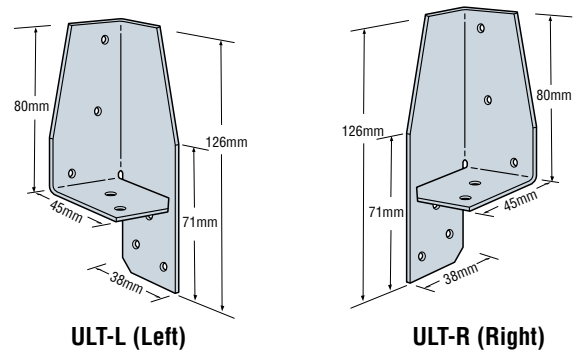
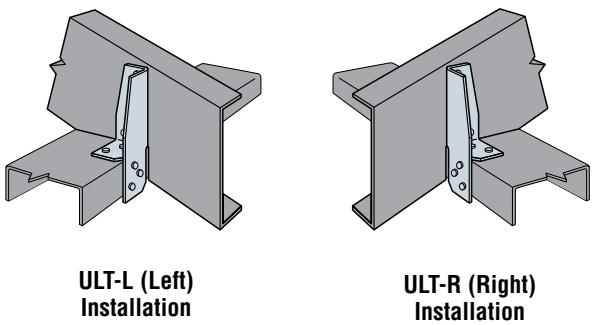
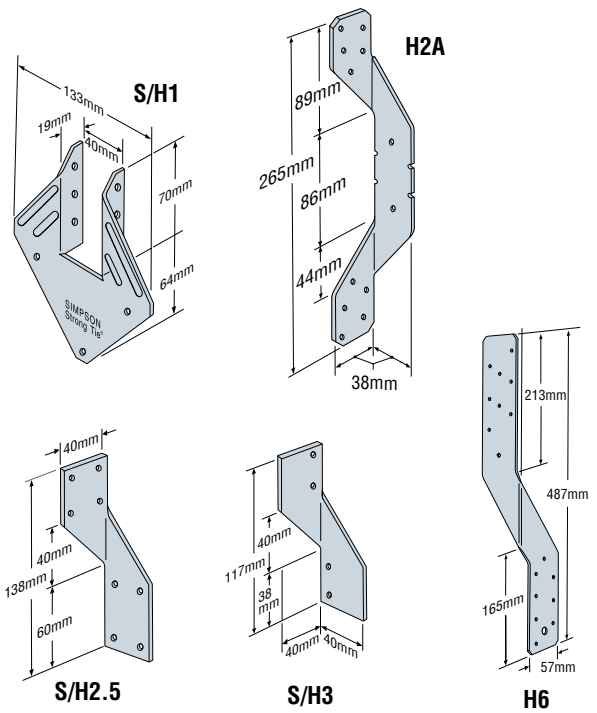
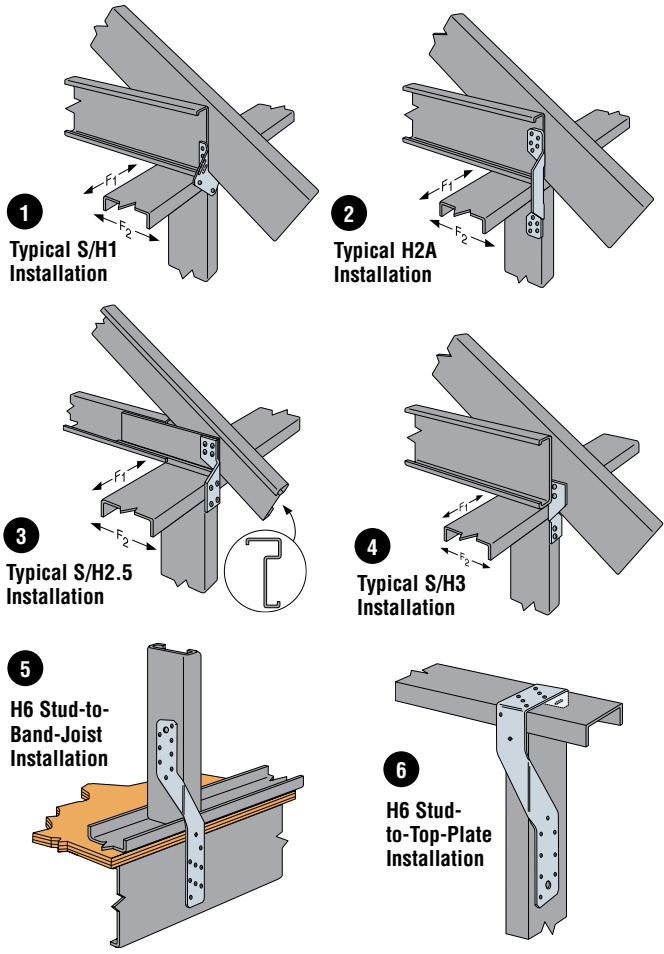

WBT Wall Brace Tensioner

The WBT is an easy to use wall strap brace tensioner that takes the slack out of strap bracing (up to 20mm) reducing deflection in braced wall panels. The WBT comes with a bolt and nut that can tension strap bracing up to 32mm wide. The WBT takes load in tension only, and should be used in pairs; one on each strap. Saves time in the field.

MATERIAL: 3mm

FINISH: Galvanised

INSTALLATION:

- Place WBT near center of diagonal wall brace.
- Install bolt through strap and WBT with nut facing towards the wall cavity.
- Tightening the nut requires 10mm hex head deep socket setter. Tighten until the slack is taken out of the strap.

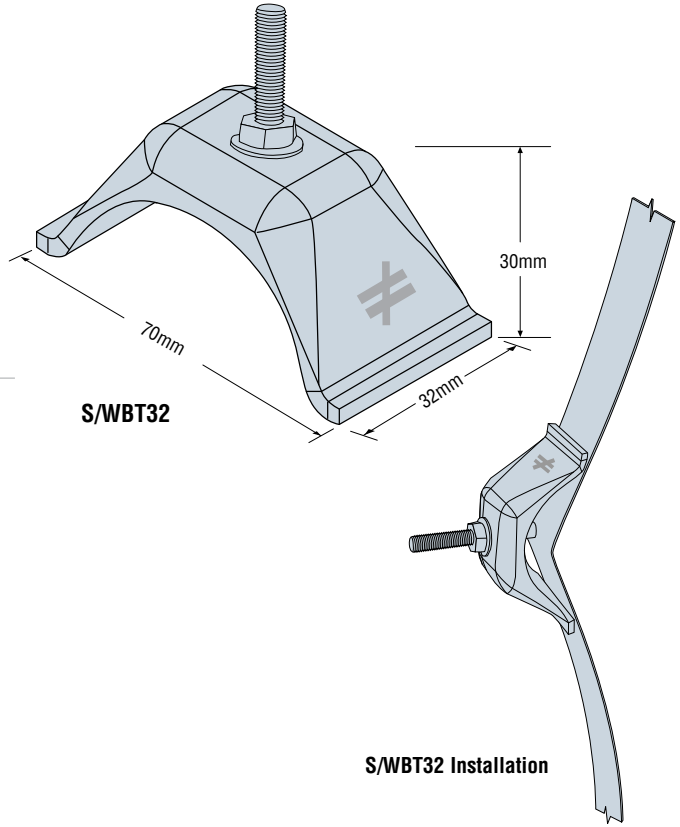

Model	Fastener	Maximum Load (kN)
S/WBT32	M6	12.7

1. Strap by Designer, load is limited to the lower of strap capacity and WBT.

Miscellaneous

TB Bridging

TB bridging is a cost effective way to provide bracing between floor joists when compared with field fabricated blocking and clip angles with multiple fasteners.

Tension-type bridging has maximum fastener flexibility. Use two 10g screws of the seven screw holes at each end.

MATERIAL: TB—0.85mm

FINISH: Galvanised

INSTALLATION:

- Bridging will fit flange widths from 38mm to 76mm.

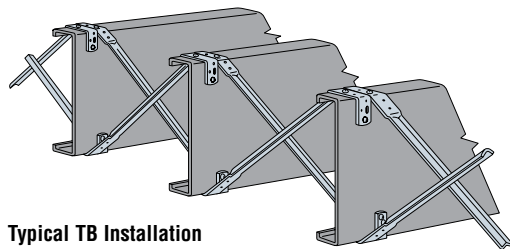
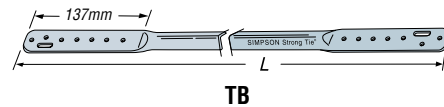

Typical TB Installation

Web Height (mm)	Spacing (on center) (mm)	TB	
		Model No.	L (mm)
305	305	TB27	686
152	406	TB27	686
203	406	TB27	686
254	406	TB27	686
305	406	TB27	686
254	610	TB36	914
305	610	TB36	914

TITEN HD® Heavy Duty Screw Anchor for Concrete

The proprietary design of the threads on the Titen HD anchor hold the key to its performance. During installation, hardened cutting teeth at the tip of the anchor undercut the concrete allowing the rest of the threads to follow with very little friction. The result is a continuous mechanical interlock between the anchor and base material that requires little installation torque.

PERFORMANCE FEATURES:

- **Cut Installation Time:** No secondary setting or torquing is required. Just drive it and you're done. Install more anchors per hour and reduce labor costs.
- **Cut Down on Tools:** Just an impact or socket wrench is all you need for installation. No need for separate tools to drive and set the anchor.
- **Cut The Hassle of Removal:** Since the Titen HD anchor is easy to remove, it is ideal for temporary anchoring or applications where fixtures may need to be moved. No torching or grinding required and no steel pieces are left in the concrete to corrode and stain.
- **Cut Lost Washers and Protruding Studs:** The hex washer head is designed to not require a separate washer and provides a clean installed appearance.
- **Higher Load Capacity:** Rather than one expansion area, the Titen HD anchor has threads along the entire length of the anchor that undercut the base material to efficiently transfer the load.
- **Vibration and Shock Resistance:** The mechanical interlock of the threads and the ratchet teeth on the underside of the head help prevent the anchor from loosening in vibratory conditions. The Titen HD anchor has been tested to 12.6 million vibratory cycles with no performance reductions.
- **Less Spacing and Edge Distance Required:** The Titen HD anchor does not exert expansion forces on the base material. This means greater placement flexibility because anchors can be placed closer to each other or closer to the edge of the base material while maintaining performance.
- **Proprietary Heat Treating Process:** Creates superior surface hardness for cutting into the hardest of base materials, while at the same time maintaining the anchor's ductility.
- **Easy Post-Installation Inspection:** The head is stamped with the Simpson Strong-Tie "≠" sign and the anchor diameter x length in mm.

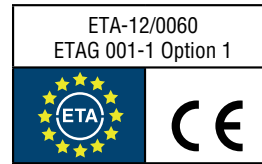

Easy Post-Installation Inspection: The head is stamped with the Simpson "≠" sign and the anchor size in mm.



Titen HD®
screw anchor



Serrated teeth on the tip of the Titen HD® screw anchor facilitate cutting and reduce installation torque.

Titen HD® Anchor Product Data - Zinc Plated

Size (mm)	Model No.	Drill Bit Dia. (mm)	Wrench Size (mm)	Quantity	
				Per Inner Box	Per Carton
THD08 x 80	THD08080	8	13	50	200
THD08 x 100	THD08100			50	200
THD08 x 120	THD08120			50	100
THD08 x 140	THD08140			50	100
THD10 x 60	THD10060	10	15	50	200
THD10 x 80	THD10080			50	200
THD10 x 90	THD10090			50	200
THD10 x 100	THD10100			50	200
THD10 x 120	THD10120			50	100
THD10 x 140	THD10140			50	100
THD10 x 160	THD10160			50	100
THD12 x 75	THD12075	12	18	20	80
THD12 x 110	THD12110			20	80
THD12 x 130	THD12130			20	80
THD12 x 150	THD12150			20	80
THD16 x 130	THD16130	16	24	10	40
THD16 x 150	THD16150			10	40
THD20 x 150	THD20150	20	30	5	20
THD20 x 170	THD20170			5	10

1. Zinc plating meets ASTM B633, SC1.
2. Length is measured from the underside of the head to the tip of the anchor.

Titen HD® Anchor Product Data - Mechanically Galvanised

Size (mm)	Model No.	Drill Bit Dia. (mm)	Wrench Size (mm)	Quantity	
				Per Inner Box	Per Carton
THD08 x 80	THD08080MG	8	13	50	200
THD08 x 100	THD08100MG			50	200
THD08 x 120	THD08120MG			50	100
THD08 x 140	THD08140MG			50	100
THD10 x 60	THD10060MG	10	15	50	200
THD10 x 80	THD10080MG			50	200
THD10 x 90	THD10090MG			50	200
THD10 x 100	THD10100MG			50	200
THD10 x 120	THD10120MG			50	100
THD10 x 140	THD10140MG			50	100
THD10 x 160	THD10160MG			50	100
THD12 x 75	THD12075MG	12	18	20	80
THD12 x 110	THD12110MG			20	80
THD12 x 130	THD12130MG			20	80
THD12 x 150	THD12150MG			20	80
THD16 x 130	THD16130MG	16	24	10	40
THD16 x 150	THD16150MG			10	40
THD20 x 150	THD20150MG	20	30	5	20
THD20 x 170	THD20170MG			5	10

1. Mechanical galvanising meets ASTM B695, Class 65, Type 1 (Minimum thickness of 65 microns zinc coating. Not for use in highly corrosive or outdoor environments.
2. MG finish ETA approval pending.

Installation Sequence**FAST AND EASY INSTALLATION:**

Once the hole is drilled, drive the anchor through the fixture and you are done. No secondary setting operation required. Installs with standard sized drill bits, no special bit to buy.

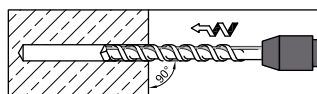

1. Drill hole

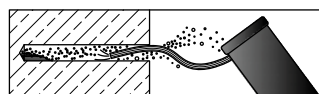

2. Clean hole

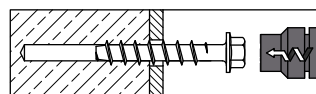

3. Set anchor with an impact wrench

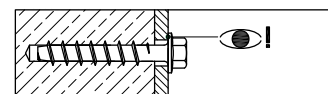

4. Check connection

PT-27 General-Purpose Tool

FEATURES:

- Reliable design of the world's most popular tool
- Semi-automatic and fast cycling
- Engineered for continuous use, high reliability and low maintenance

SPECIFICATIONS:

- Fastener Type: 8 mm headed fasteners or 6.5 mm-20 threaded studs
- Fastener Length: 22 mm through 72 mm
- Washered Fastener: 27 mm through 72 mm
- Firing Action: Semi-automatic
- Load Caliber: .27 strip loads, brown through red (Levels 2-5)
- Length: 342.9 mm
- Weight: 2.38 kg.

KEY FASTENING APPLICATIONS:

- Acoustical ceilings
- Electrical applications
- Framing members
- Drywall track
- Water proofing material and/or lathing

TOOL IS SOLD IN RUGGED FIXTURED TOOL BOX COMPLETE WITH:

- Operator's manual
- Spall suppressor
- Tools for disassembly
- Safety glasses / ear plugs
- Tool lubricant
- Cleaning brushes
- Operator's exam and caution sign

OPTION:

- Extension pole tool available in 1.8 m and 2.4 m lengths.



PT-27



For the full range of Simpson Strong-Tie® Powder Loads and Fasteners refer to S-SAS-PGAU12

CORROSION INFORMATION

General Simpson Strong-Tie Recommendations (Using connectors in damp, wet environments or with chemically treated timber).

- Outdoor environments are generally more corrosive to steel. If you choose to use ZMAX or HDG on an outdoor project (*i.e. deck, patio cover*), you should periodically inspect your connectors and fasteners or have a professional inspection performed. Regular maintenance including water-proofing of the wood used in your outdoor project is also a good practice.
- For timber with actual retention levels greater than 6.41 kg/m³ for ACQ and MCQ, 6.57 kg/m³ for CBA-A, or 3.36 kg/m³ for CA-B (*Ground Contact*), Stainless Steel connectors and fasteners are recommended. Verify actual retention level with the wood treater.
- When using Stainless Steel connectors, use Stainless Steel fasteners. When using ZMAX/HDG galvanised connectors, use fasteners that meet the specifications of ASTM A153.
- Testing indicates timber installed dry reduces potential corrosion. If dry wood is used, see our website for additional information.
- Using a barrier membrane can provide additional corrosion protection, see Technical Bulletin T-PTBARRIER on website.
- Due to the many variables involved, Simpson Strong-Tie cannot provide estimates on service life of connectors, anchors or fasteners. We suggest that all users and specifiers also obtain recommendations for HDG, ZMAX, mechanically galvanised, or other coatings from the treated timber supplier for the type of timber used. However, as long as the Simpson Strong-Tie recommendations are followed, Simpson Strong-Tie stands behind its product performance and our standard warranty page applies.

Guidelines for Selecting the Proper Connector

1 Evaluate the Application.

Consider the type of structure and how it will be used. These recommendations may not apply to non-structural applications such as fences.

2 Evaluate the Environment.

Testing and experience indicate that indoor dry environments are less corrosive than outdoor environments. Determining the type of environment where a connector or fastener will be used is an important factor in selecting the most appropriate material and finish for use on the connectors and fasteners. To help in your decision making, consider the following general exposure information:

Interior Dry Use: Includes wall and ceiling cavities, and raised floor applications of enclosed buildings that have been designed to ensure that condensation and other sources of moisture do not develop.

Exterior – Dry: Includes outdoor installations in low rainfall environments and no regular exposure to moisture.

Exterior – Wet: Includes outdoor installations in higher moisture and rainfall environments.

Higher Exposure Use: Includes exposure to ocean salt air, fire retardants, large bodies of water, fumes, fertilisers, soil, some preservative treated woods, industrial zones, acid rain, and other corrosive elements.

3 Evaluate and select a suitable pressure-treated wood for the intended application and environment.

The treated timber supplier should provide all the information needed regarding the timber being used. This information should include: the specific type of timber treatment used, if ammonia was used in the treatment, and the chemical retention level. If the needed information is not provided then Simpson Strong-Tie would recommend the use of Stainless Steel connectors and fasteners. You should also ask the treated timber supplier for a connector coating or material recommendation.

4 Use the chart on the page 19, which was created based on Simpson Strong-Tie testing and experience to select the connector finish or material.

If a pressure treated timber product is not identified on the chart, Simpson Strong-Tie has not evaluated test results regarding such product and therefore cannot make any recommendation other than the use of Stainless Steel with that product. Manufacturers may independently provide test results or other product use information; Simpson Strong-Tie expresses no opinion regarding any such information.

5 Compare the treated wood supplier's recommendation with the Simpson Strong-Tie recommendation.

If these recommendations are different, Simpson Strong-Tie recommends that the most conservative recommendation be followed.

CORROSION INFORMATION

Low = Use Simpson Strong-Tie standard painted and G90 galvanised connectors as a minimum.

Med = Use ZMAX/HDG galvanised connectors as a minimum. Use fasteners which meet the specifications of ASTM A153 or SDS screws with double-barrier coating.



High = Use Type 303, 304(A2), 305 or 316(A4) Stainless Steel connectors and fasteners.

CONNECTOR COATING RECOMMENDATION – STRUCTURAL APPLICATIONS

Environment	Untreated Wood	SBX/ DOT & Zinc Borate	MCQ	ACQ-C, ACQ-D (Carbonate), CA-B & CBA-A			ACZA	Other or Uncertain
				No Ammonia	With Ammonia	Higher Chemical Content ¹		
Interior – Dry	Low	Low	Low ⁵	Med ⁵	Med	High	High	High
Exterior – Dry	Low	N/A ²	Med	Med	High	High	High	High
Exterior – Wet	Med	N/A ²	Med ^{3,4}	Med ^{3,4}	High	High	High	High
Higher Exposure	High	N/A ²	High	High	High	High	High	High
Uncertain	High	N/A ²	High	High	High	High	High	High

- Timber with actual retention levels greater than 6.41 kg/m³ for ACQ and MCQ, 6.57 kg/m³ for CBA-A, or 3.36 kg/m³ for CA-B (Ground Contact level).
- Borate treated timber are not appropriate for outdoor use.
- Test results indicate that ZMAX/HDG and the SDS double-barrier coating will perform adequately, subject to regular maintenance and periodic inspection. However, the nationally-approved test method used, AWWPA E12-94, is an accelerated test, so data over an extended period of time is not available. If uncertain, use stainless steel.
- Some treated timber may have excess surface chemicals making it potentially more corrosive. If you suspect this or are uncertain, use stainless steel.
- Where noted in the table, applications where the timber is dry (moisture content less than 19%) when installed and will remain dry in-service may use a minimum coating recommendation of "Low".
- Type 316(A4) stainless-steel connectors and fasteners are the minimum recommendation for ocean-salt air and other chloride environments.

COATINGS AVAILABLE Not all products are available in all finishes. Contact Simpson Strong-Tie for product availability, ordering information and lead times.

Finish	Description	Level of Corrosion Resistance
Gray Paint	Water-based paint intended to protect the product while it is warehoused and in transit to the jobsite.	Low
Powder Coating	Baked on paint finish that is more durable than our standard paint and produces a better looking finished product.	Low
Standard G90 Zinc Coating	Zinc galvanised finish containing 0.90 oz. of zinc per square foot of surface area(275 grams/m ²)(total both sides).	Low
	Galvanised (G185) 1.85 oz. of zinc per square foot of surface area(565 grams/m ²)(hot-dip galvanised per ASTM A653 total both sides). These products require hot-dip galvanised fasteners (fasteners which meet the specifications of ASTM A153).	Medium
	Products are hot-dip galvanised after fabrication 1.74mm and thicker. The coating weight increases with material thickness. The minimum specified coating weight is 2.0 oz./ft ² (610 grams/m ²)(per ASTM A123 total both sides). These products require hot-dip galvanised fasteners (fasteners which meet the specifications of ASTM A153).	Medium
Double-Barrier Coating (SDS Screws)	SDS screws that are manufactured with two different finishes that provide a level of corrosion protection that is equivalent to that provided by the previous HDG finish.	Medium
	Products manufactured from Type 316L(A4) stainless steel, and provide greater durability against corrosion. Stainless steel nails are required with stainless steel products, and are available from Simpson Strong-Tie.	High

See Corrosion Information for more specific performance and application information on these finishes.



www.strongtie.com.au

www.strongtie.co.nz

www.strongtie.co.za

Simpson Strong-Tie Australia

SYDNEY OFFICE

Unit 1/16 Kenoma Place
Arndell Park, NSW 2148
Australia

Tel: (61) 2 9831 7700
Fax: (61) 2 9831 2726

Simpson Strong-Tie Australia

PERTH OFFICE

54A Boulder Road,
Malaga, WA 6090
Australia

Tel: (61) 8 9248 6002
Fax: (61) 8 9248 4007

Simpson Strong-Tie New Zealand

28 Arrenway Drive
Albany, Auckland 0632
New Zealand

Tel: (64) 9 477 4440
Fax: (64) 9 475 9724

Simpson Strong-Tie South Africa

Unit 5 Fairway Business Park
Stibitz Street, Westlake
Cape Town Western Province 7945
South Africa

Tel: (27) 87 354 0629
Fax: (27) 21 702 3679